

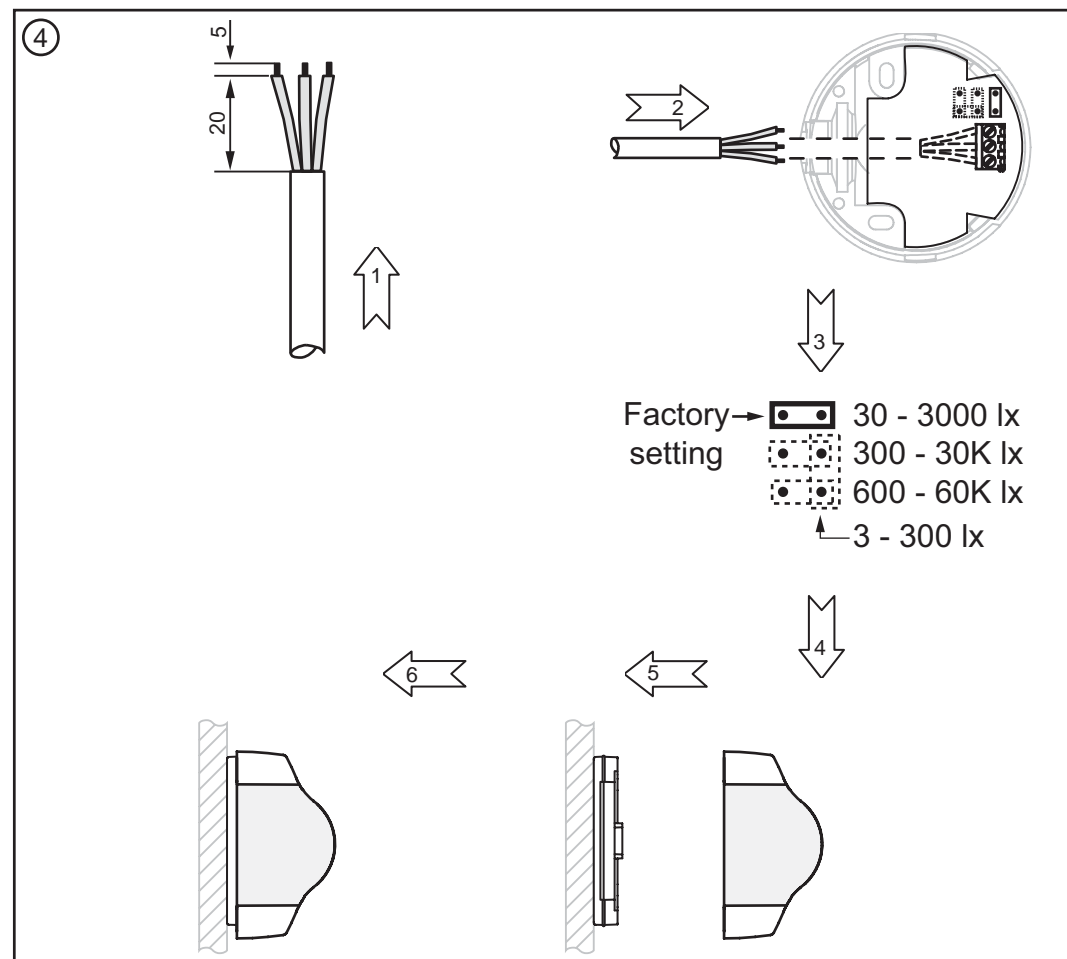

Light Sensor 43-197

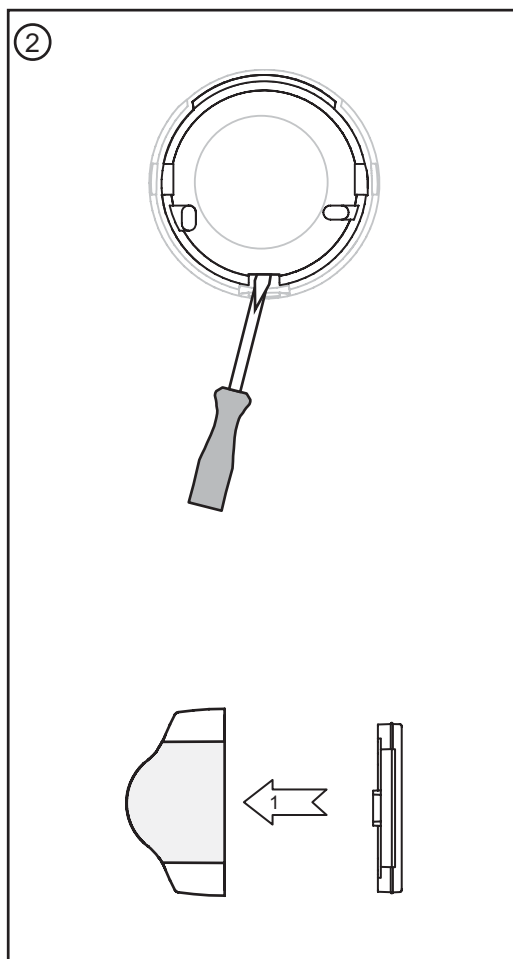
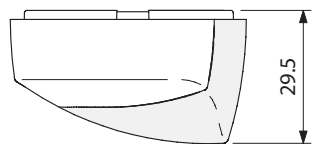
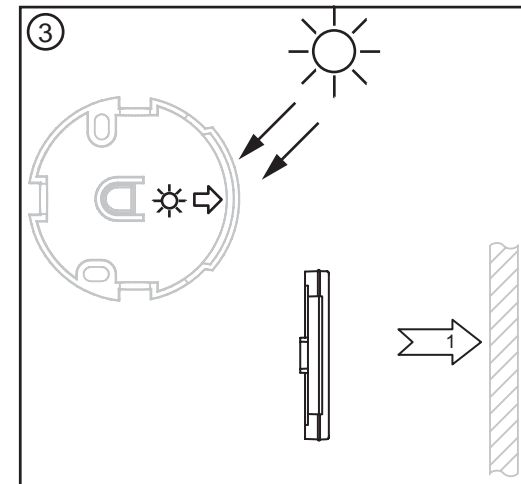
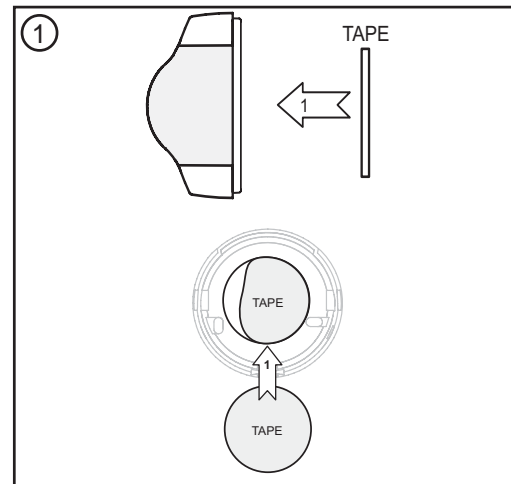
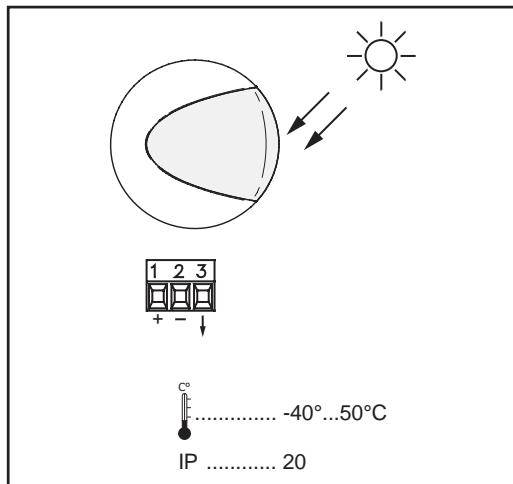
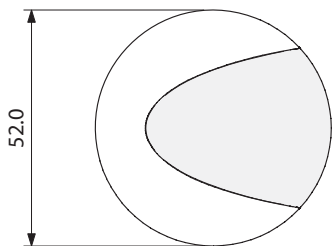

Advarsel: Indbygning og montering af elektriske apparater må kun foretages af aut. elinstallatør.
 Ved fejl eller driftforstyrrelser kontakt den aut. elinstallatør.
! Ret til ændringer forbeholdes !

Warning: Installation and assembly of electrical equipment must be carried out by qualified electricians.
 Contact a qualified electrician in the event of fault or breakdown.
! Reserving the right to make changes !

Achtung: Einbau und Montage elektrischer Geräte dürfen nur durch Elektrofachkräfte erfolgen.
 Wenden Sie sich bei Störungen bzw. Ausfall an einen Elektrofachkraft.
! Änderungen vorbehalten !

Avertissement : L'installation et le montage d'appareils électriques doivent exclusivement être exécutés par un électricien agréé.
 En cas de défaut ou de perturbation du fonctionnement, contacter un installateur électricien agréé.
! Sous réserve de modifications !

Servodan A/S • DK-6400 Sønderborg
 Tel.: +45 7442 4726 • Fax: +45 7442 4035
 www.servodan.dk • E-mail: info@servodan.dk

43Y197_03_R2_051208KOE1532

